

High Voltage Power Operational Amplifiers

FEATURES

- ◆ HIGH VOLTAGE — 900V ($\pm 450V$)
- ◆ HIGH SLEW RATE — $500V/\mu S$
- ◆ HIGH OUTPUT CURRENT — 100mA
- ◆ PROGRAMMABLE CURRENT LIMIT

APPLICATIONS

- ◆ HIGH VOLTAGE INSTRUMENTATION
- ◆ PROGRAMMABLE POWER SUPPLIES UP TO $\pm 430V$
- ◆ MASS SPECTROMETERS
- ◆ SEMICONDUCTOR MEASUREMENT EQUIPMENT

DESCRIPTION

The PA94 is a high voltage, MOSFET operational amplifier designed as a low cost solution for driving continuous output currents up to 100mA and pulse currents up to 200mA into capacitive loads. The safe operating area (SOA) has no second breakdown limitations and can be observed for all load types by choosing an appropriate current limiting resistor. The MOSFET output stage is biased AB for linear operation. External compensation provides flexibility in choosing bandwidth and slew rate for the application. Cirrus's Power SIP package uses a minimum of board space allowing for high density circuit boards.. The Power SIP package is electrically isolated. Isolating thermal washers (TW13) prevent arcing from pins to heatsink.

EQUIVALENT SCHEMATIC

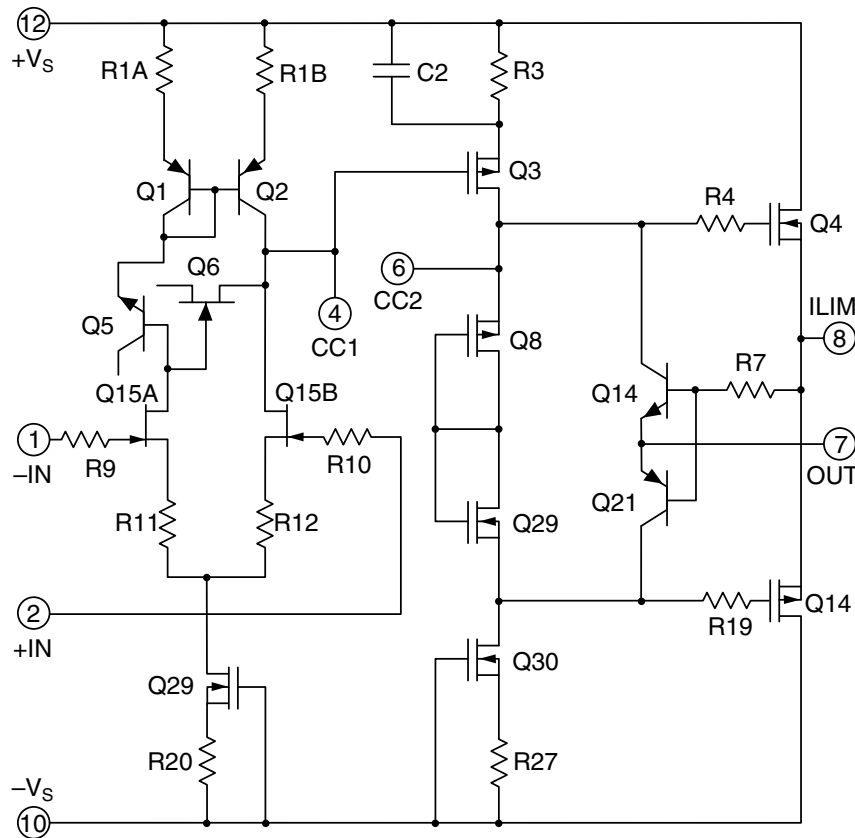

CHARACTERISTICS AND SPECIFICATIONS

ABSOLUTE MAXIMUM RATINGS

Parameter	Symbol	Min	Max	Units
SUPPLY VOLTAGE, +V _s to -V _s			900	V
OUTPUT CURRENT, source, sink, within SOA			200	mA
POWER DISSIPATION, continuous @ T _c = 25°C			30	W
INPUT VOLTAGE, differential		-20	20	V
INPUT VOLTAGE, common mode (Note 3)		-V _s	V _s	V
TEMPERATURE, pin solder, 10s max.			260	°C
TEMPERATURE, junction (Note 2)			150	°C
TEMPERATURE RANGE, storage		-40	85	°C
OPERATING TEMPERATURE RANGE, case		-25	85	°C

CAUTION The PA94 is constructed from MOSFET transistors. ESD handling procedures must be observed. The exposed substrate contains beryllia (BeO). Do not crush, machine, or subject to temperatures in excess of 850°C to avoid toxic fumes.

SPECIFICATIONS

Parameter	Test Conditions ¹	Min	Typ	Max	Units
INPUT					
OFFSET VOLTAGE, initial			0.5	5	mV
OFFSET VOLTAGE vs. temperature	Full temperature range		15	50	μV/°C
OFFSET VOLTAGE vs. supply			10	25	μV/V
OFFSET VOLTAGE vs. time			75		μV/kHz
BIAS CURRENT, initial			200	2000	pA
BIAS CURRENT vs. supply			4		pA/V
OFFSET CURRENT, initial			50	500	pA
INPUT IMPEDANCE, DC			10 ¹¹		Ω
INPUT CAPACITANCE			4		pF
COMMON MODE VOLTAGE RANGE (Note 3)	V _s = ±450V	±V _s ±30			V
COMMON MODE REJECTION, DC	V _{CM} = ±90V	80	98		dB
NOISE	10KHz bandwidth, R _s = 1KΩ		2		μV RMS
GAIN					
OPEN LOOP @ 15Hz	R _L = 5KΩ	94	115		dB
GAIN BANDWIDTH PRODUCT @ 1MHz	R _L = 5KΩ		140		MHz
POWER BANDWIDTH	R _L = 5KΩ		300		kHz
PHASE MARGIN, A _v = 100	Full temp range		60		°
OUTPUT					
VOLTAGE SWING	I _o = 70mA	±V _s ±24	±V _s ±20		V
CURRENT, continuous		100			mA
SLEW RATE, A _v = 100	C _c = 2.2pF	500	700		V/μS
SETTLING TIME, to 0.1%	2V Step		1		μS
RESISTANCE	no load		100		Ω

Parameter	Test Conditions ¹	Min	Typ	Max	Units
POWER SUPPLY					
VOLTAGE (Note 5)		±50	±300	±450	V
CURRENT, quiescent total			17	24	mA
CURRENT, quiescent output stage only				120	µA
THERMAL					
RESISTANCE, AC, junction to case (Note 4)	Full temp range, F > 60Hz			2.5	°C/W
RESISTANCE, DC, junction to case	Full temp range, F < 60Hz			4.2	°C/W
RESISTANCE, junction to air	Full temp range		30		°C/W
TEMPERATURE RANGE, case	Meets full range specifications	-25		+85	°C

- NOTES: 1. Unless otherwise noted: T_C = 25°C, DC input specifications are ± value given. Power supply voltage is typical rating. C_c = 4.7pF.
2. Long term operation at the maximum junction temperature will result in reduced product life. Derate internal power dissipation to achieve high MTTF.
3. Although supply voltages can range up to ± 450V the input pins cannot swing over this range. The input pins must be at least 30V from either supply rail but not more than 450V from either supply rail. See text for a more complete description of the common mode voltage range.
4. Rating applies if the output current alternates between both output transistors at a rate faster than 60Hz.
5. Derate max supply rating 0.625 V/°C below 25°C case. No derating needed above 25°C case.

EXTERNAL CONNECTIONS

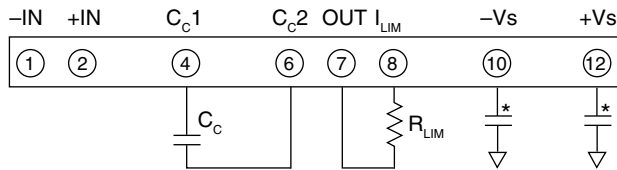

* 0.01µF or greater ceramic power supply bypassing required.



PATENTED

**8-pin SIP
PACKAGE
STYLE DQ**

Formed leads available
See package style EC

PHASE COMPENSATION

GAIN	C _c
≥100	2.2pF
≥50	4.7pF
≥10	22pF

C_c rated for full supply voltage.

$$R_{LIM} = \frac{.7}{I_{LIM}}$$

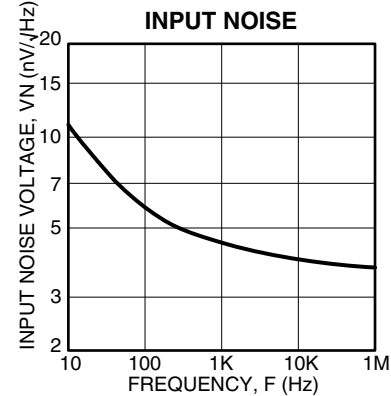
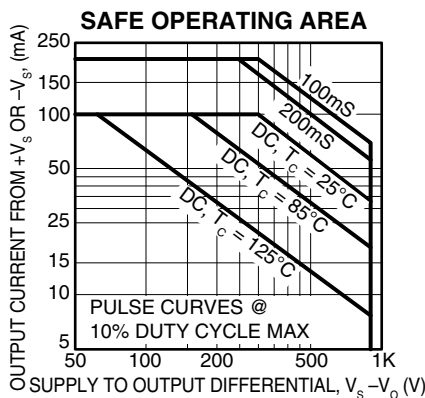
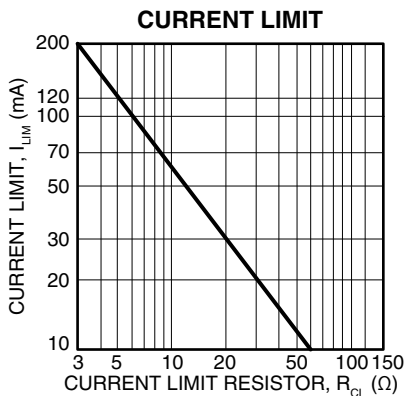
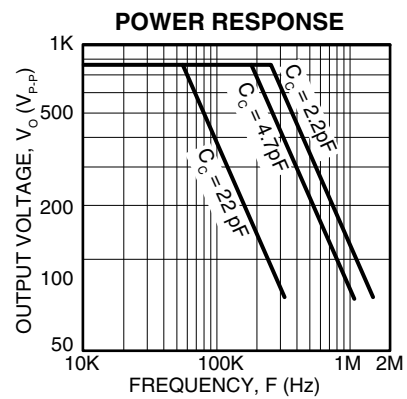
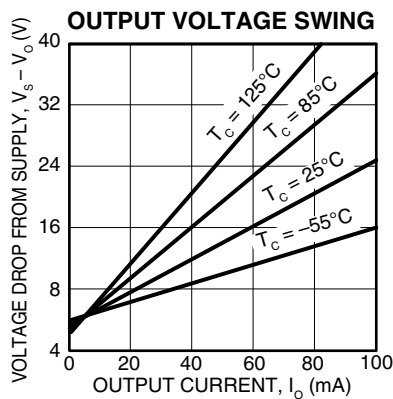
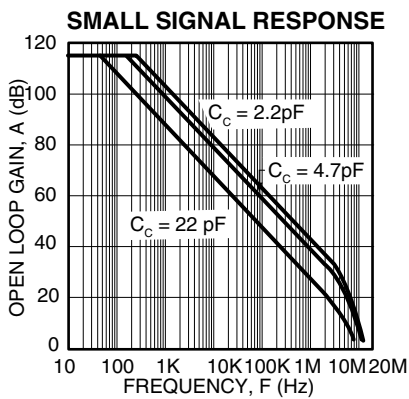
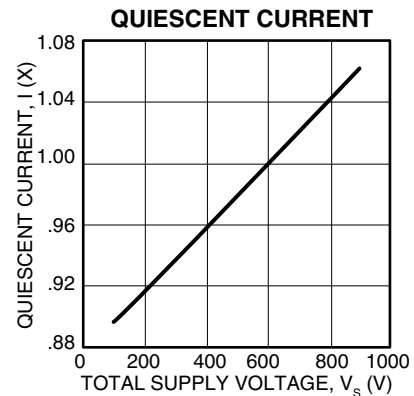
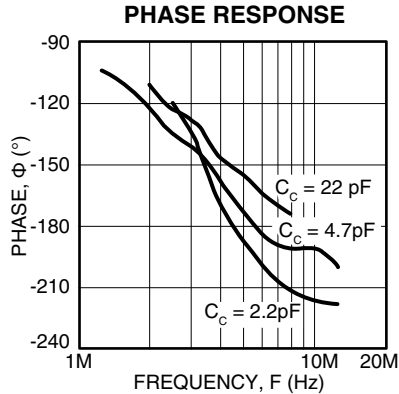
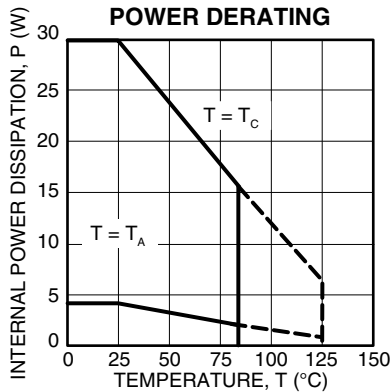

TYPICAL APPLICATION

Piezo positioning may be applied to the focusing of segmented mirror systems. The composite mirror may be composed of hundreds of elements, each requiring focusing under computer control. In such complex systems the PA94 reduces the costs of power supplies and cooling with its advantages of low cost and low quiescent power consumption while increasing circuit density with the SIP package.

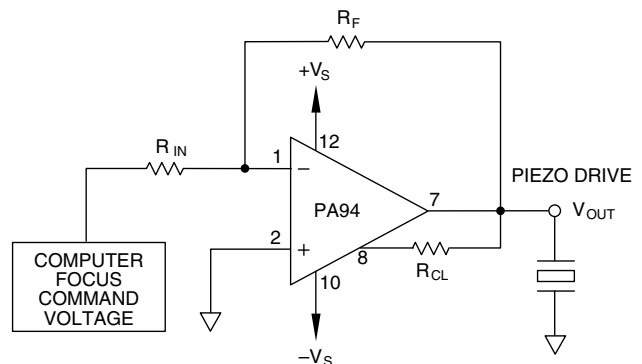

INTERNAL POWER DISSIPATION AND HEATSINK SELECTION

With the unique combination of high voltage and speed of the PA94, traditional formulas for heatsink selection will falsely lower the apparent power handling capability of this amplifier. To more accurately predict operating temperatures use Power Design¹ revision 10 or higher, or use the following procedure:

Find internal dissipation (PD) resulting from driving the load. Use Power Design or refer to Cirrus Applications Note 1, General Operating Considerations, paragraph 7. Find total quiescent power (PD_Q) by multiplying 0.024A by V_{SS} (total supply voltage). Find output stage quiescent power (PD_{QOUT}) by multiplying 0.00012 by V_{SS}.

Calculate a heatsink rating which will maintain the case at 85°C or lower.

$$R_{\theta SA} = \frac{T_C - T_A}{PD + PD_Q} - 0.1^\circ\text{C/W}$$

Where: T_C = maximum case temperature allowed

T_A = maximum ambient temperature encountered

Calculate a heatsink rating which will maintain output transistor junctions at 150°C or lower.

$$R_{\theta SA} = \frac{T_J - T_A - (PD + PD_{QOUT}) * R_{\theta JC}}{PD + PD_Q} - 0.1^\circ\text{C/W}$$

Where: T_J = maximum junction temperature allowed.

R_{θJC} = AC or DC thermal resistance from the specification table.

Use the larger heatsink of these two calculations.

Power Design is an Excel spreadsheet available free from www.cirrus.com

GENERAL

Please read Application Note 1 "General Operating Considerations" which covers stability, supplies, heat sinking, mounting, current limit, SOA interpretation, and specification interpretation. Visit www.cirrus.com for design tools that help automate tasks such as calculations for stability, internal power dissipation, current limit; heat sink selection; Cirrus's complete Application Notes library; Technical Seminar Workbook; and Evaluation Kits.

CURRENT LIMIT

For proper operation, the current limit resistor (R_{LIM}) must be connected as shown in the external connection diagram. The minimum value is 3.5 ohm, however for optimum reliability the resistor value should be set as high as possible. The value is calculated as follows; with the maximum practical value of 30 ohms.

$$R_{LIM} = \frac{.7}{I_{LIM}}$$

COMMON MODE INPUT RANGE

Operational amplifiers are usually designed to have a common mode input voltage range that approximates the power supply voltage range. However, to keep the cost as low as possible and still meet the requirements of most applications the common mode input voltage range of the PA94 is restricted. The input pins must always be a least 30V from either supply voltage but never more than 450V. This means that the PA94 cannot be used in applications where the supply voltages are extremely unbalanced. For example, supply voltages of +800V and -100V would not be allowed in an application where the non-inverting pin is grounded because in normal operation both input pins would be at 0V and the difference voltage between the positive supply and the input pins would be 800V. In this kind of application, however, supply voltages +450V and -100V does meet the input common mode voltage range requirements since the maximum difference voltage between the inputs pins and the supply voltage is 450V (the maximum allowed). The output has no such restrictions on its voltage swing. The output can swing within 24V of either supply voltage regardless of value so long as the total supply voltage does not exceed 900V.

INPUT PROTECTION

Although the PA94 can withstand differential input voltages up to $\pm 20V$, additional external protection is recommended. In most applications 1N4148 or 1N914 signal diodes are sufficient (D1, D2 in Figure 1a). In more demanding applications where low leakage or low capacitance are of concern 2N4416 or 2N5457-2N5459 JFETs connected as diodes will be required (Q1, Q2 in Figure 1b). In either case the input differential voltage will be clamped to $\pm 7V$. This is sufficient overdrive to produce maximum power bandwidth. Note that this protection does not automatically protect the amplifier from excessive common mode input voltages.

POWER SUPPLY PROTECTION

Unidirectional zener diode transient suppressors are recommended as protection on the supply pins. The zeners clamp transients to voltages within the power supply rating and also clamp power supply reversals to ground. Whether the zeners are used or not, the system power supply should be evaluated for transient performance including power-on overshoot and power-off polarity reversal as well as line regulation.

Conditions which can cause open circuits or polarity reversals on either power supply rail should be avoided or protected against. Reversals or opens on the negative supply rail is known to induce input stage failure. Unidirectional transzorbors prevent this, and it is desirable that they be both electrically and physically as close to the amplifier as possible.

STABILITY

The PA94 is stable at gains of 100 or more with a NPO (COG) compensation capacitor of 2.2pF. The compensation capacitor, C_c , in the external connections diagram must be rated at 1000V working voltage and mounted closely to pins 4 and 6 to prevent spurious oscillation. A compensation capacitor less than 2.2pF is not recommended.

EXTERNAL COMPONENTS

The compensation capacitor C_c must be rated for the total supply voltage. An NPO (COG) capacitor rated a 1kV is recommended.

Of equal importance are the voltage rating and voltage coefficient of the gain setting feedback resistor. Typical voltage ratings of low wattage resistors are 150 to 250V. Up to 500 V can appear across the feedback resistor. High voltage rated resistors can be obtained. However a 1 megohm feedback resistor composed of five 200k resistors in series will produce the proper voltage rating.

CAUTIONS

The operating voltages of the PA94 are potentially lethal. During circuit design develop a functioning circuit at the lowest possible voltages. Clip test leads should be used for "hands off" measurements while troubleshooting.

FIGURE 1. OVERVOLTAGE PROTECTION

