

# Jumper Configurable 400 Watt+ DC-to-DC Converter Fulfills Buck-Boost & Motor Drive Roles

## INTRODUCTION

This Application Note describes a novel DC converter design concept that uses the SA306-IHZ monolithic three-phase switching amplifier<sup>1,2</sup>. The converter is depicted schematically in Figure 1. It can be thought of as a ‘black box’ module that is suitable for a variety of applications such as converting +28 volts to -48 volts (relative to the +28 volt input) and -20 volts (relative to the -28 volt input), and able to deliver a minimum of 8.5 amperes of combined output. The module is jumper configurable as a positive or negative input converter. A minor circuit change (Figure 1, Note 5) allows the module to convert +48 volts to +20 volts at 15 amperes of output (representing 91% efficiency), or -48 volts converted to -28 volts with 14 amperes (a 93% efficiency). For simplicity’s sake, the design is limited in scope but has proven to be quite usable and robust despite the limitations listed below, and in the section entitled Miscellaneous Design Notes on page 9. This design assumes a well regulated voltage input because of limited loop gain. The output voltage regulation is  $\pm 1\%$  to  $\pm 3\%$  over the full output load range with an input voltage delta of 300 mV. There is no boost mode current limit circuit included for a number of reasons, one of which is that the input is diode coupled to the output — output currents in excess of 15 A will exceed the diode current/wire bond ratings. Transient load response is quite good with full recovery in about 3 milliseconds. Efficiencies of approximately 94% are realized with a 48 V output and approximately 85% with the 20 V output, as depicted in the application illustrations that follow.

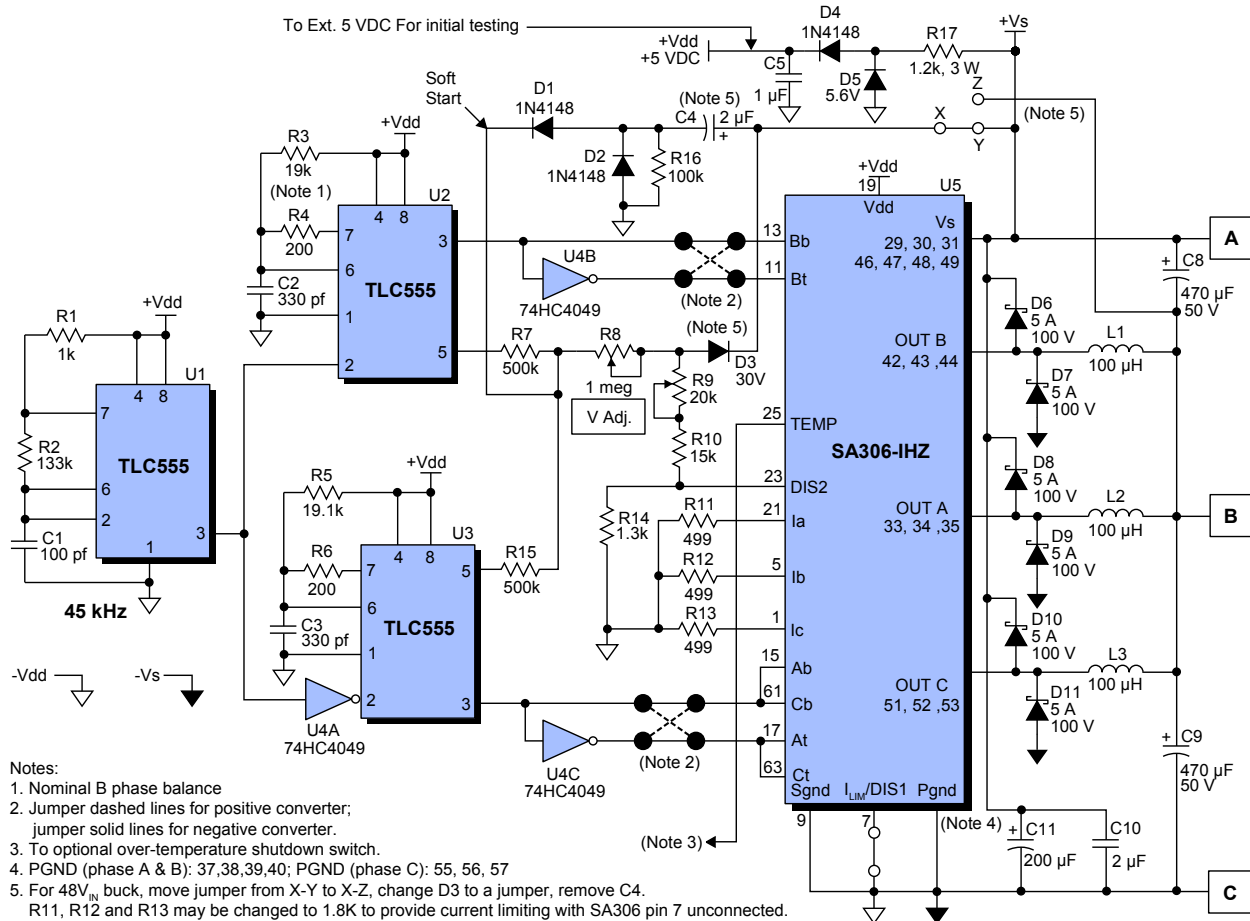
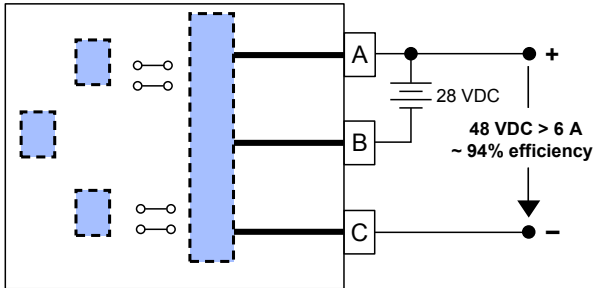

**Figure 1. Polarity is Easily Switched** — DC-to-DC converter, three terminal module can be switched from a positive to a negative converter by simply interchanging the jumpers identified by Note 2. (**Caution:** Make sure the A,B,C terminal connections correspond to the new configuration, otherwise the SA306-IHZ will be destroyed when power is applied.)

**APPLICATIONS**

In the following panel are shown a number of buck, boost and motor applications.

**Buck-Boost Applications**



**Negative Converter**

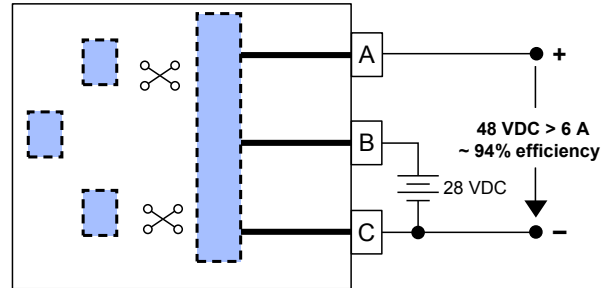

**Positive Converter**

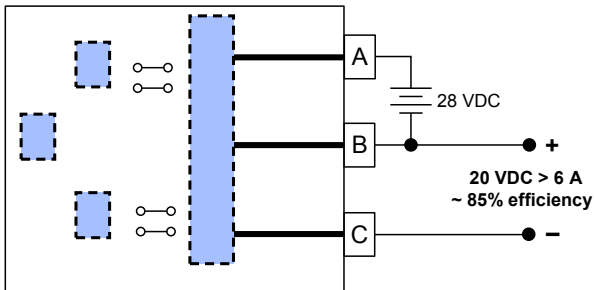

**Negative Converter**

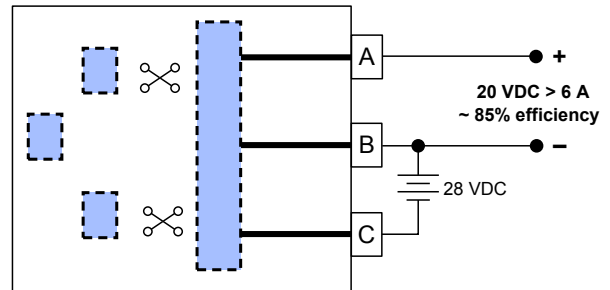

**Positive Converter**

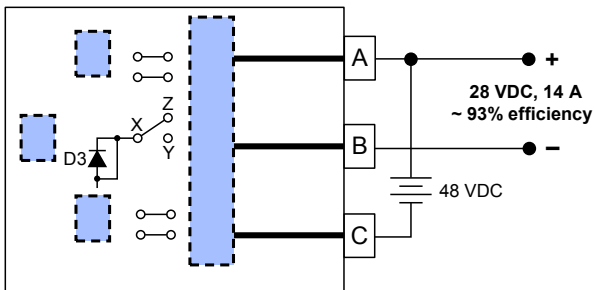

**Buck Negative Converter**

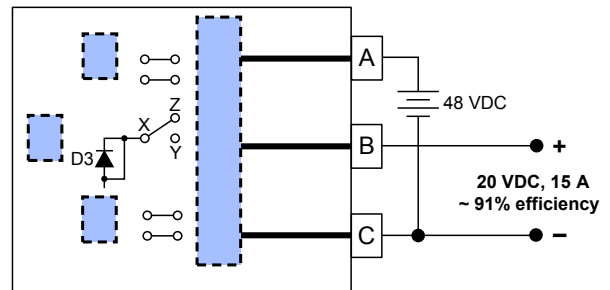

**Buck Negative Converter**

**Motor Drive Applications**

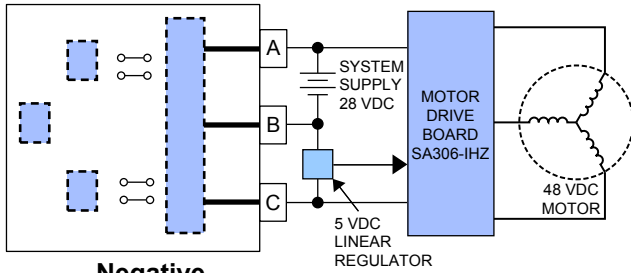

**Negative Converter**

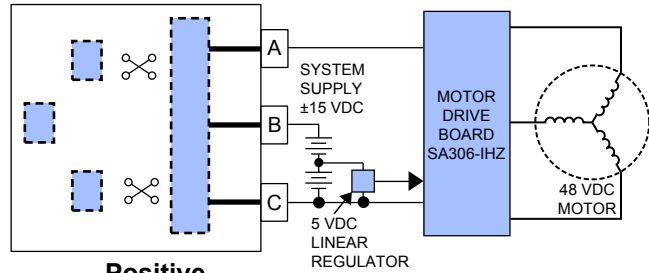

**Positive Converter**

**Battery Applications**

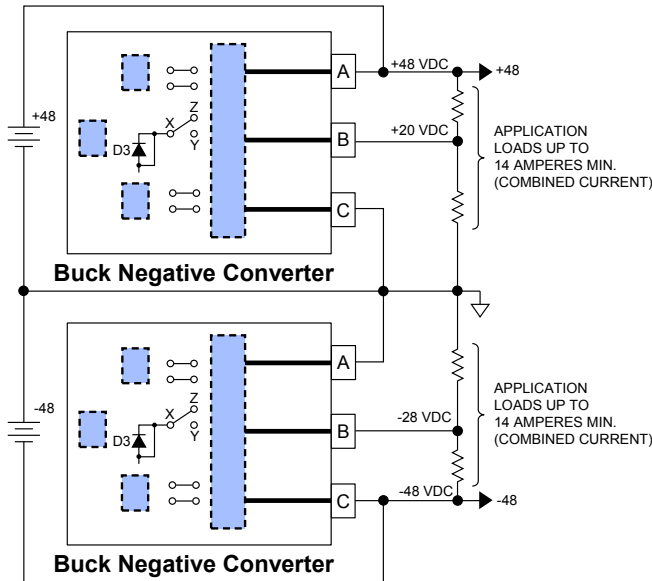

Note: Converters are adjustable via the R8 potentiometer - C to B voltage Adjusts from 16 to 22 V while B to A voltage adjusts from 32 to 26 V Simultaneously (48 V total). The maximum output per module is the lesser of 400 watts combined output power or 15 amperes combined output current. It should be noted that the series loads shown above will divide the input voltage if a converter shuts down (thermal limit, etc). See Figure 1, Note 5 for recommended current limiter.

U1, U2, U3, U4 and much of the associated circuitry could be replaced with an inexpensive micro-controller to provide other functions and voltage ranges than those shown above for all applications resulting in a low cost, low parts count converter module.

### Theory of Operation – PWM Circuitry

The drive circuit shown in Figure 1 comprises three Texas Instruments TLC555 CMOS Timers, as well as the left block in Figure 2. In Figure 1, U1 serves as a 45 kHz oscillator. It, in turn, drives U2 and U3 which can be thought of as pulse width modulators (PWMs). As can be seen in Figure 1, U4A inverts the input to U3 so that it operates out of phase with its companion, U2. Even though the SA306-IHZ is a three-phase device with three sets of MOSFET half bridges, A, B and C operate in this application as a two-phase switch. Notice at the bottom of Figure 2 that Ab and Cb, as well as At and Ct are tied together, transforming the operation of the SA306-IHZ in to a two-phase operation. The two waveforms shown in Figure 2 are there to underscore the fact that the B phase (Bt and Bb) and the A & C phases (Ab, Cb) and (At, Ct), are always driven out of phase with each other. These out-of-phase signals toggle the inputs to the MOSFETs in the switching amplifier SA306-IHZ (U5). This alternating toggle arrangement distributes the power properly within the SA306-IHZ die, allowing maximum current throughput and reducing ripple current.

**Maximum On Time** – Because the Oscillator U1 is set at 45 kHz by timing components R1, R2 and C1, the period of the oscillator is 22 microseconds. The maximum ON time is 50%. Raising the voltage on U2 and U3 would provide a slight variation. This is employed in the Slow Start circuitry discussed in the “Charge Dynamics” section that follows. Raising the voltage applied to pin 5 of U2 and U3 raises the deadtime by increasing the threshold of these devices so the OFF time is extended. As the voltage applied through R7 and R15 goes up, the OFF time becomes longer.

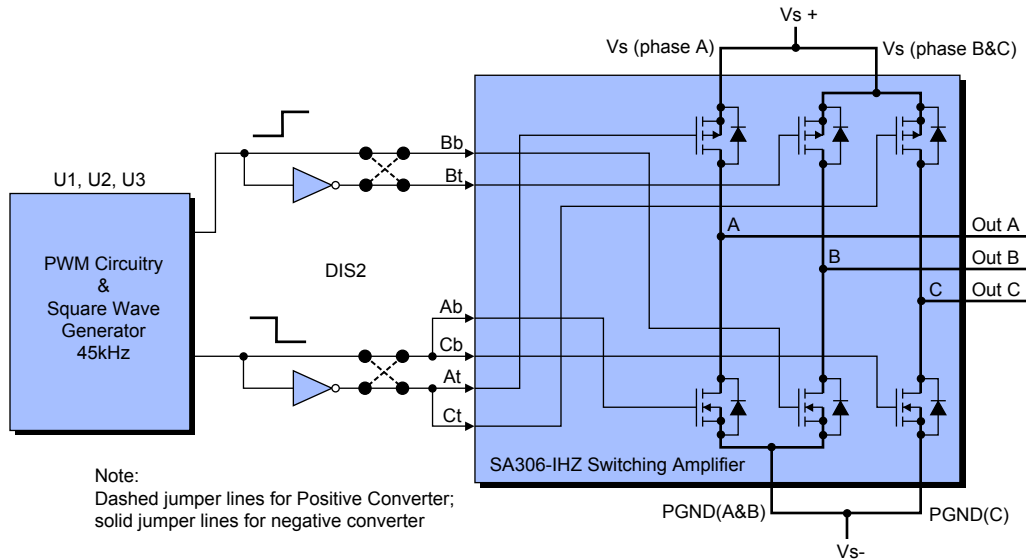

Figure 2. PWM Circuitry Interface with the SA306-IHZ Inputs – Simplified

## Boost Circuitry

The voltage change technique employed in this converter is often called 'Boost Circuitry'. Each input inductor is charged through one SA306-IHZ output switch during a PWM 'charge' interval and then is synchronously rectified by the alternate MOSFET output switch during the PWM 'discharge' interval. Or to put it another way, energy is loaded into inductor L1, L2, or L3 and is then, during the discharge interval, delivered as a current to the output capacitors and/or the load. Because the PWM ON time is limited by design to 50% maximum, the voltage delivered at the output of the converter is limited to approximately twice  $V_s$  – which is the voltage delivered by the source. This inherent voltage limiting occurs because the 'synchronous rectifier' remains on during the entire PWM 'discharge' time and then transfers the current back from the output capacitor into the input capacitor. Note that in both the positive and negative versions of this converter, the current exits the SA306-IHZ, at either  $V_{s+}$  or  $V_{s-}$ , entering the attached load.

A Soft Start circuit is required to confine turn on input current transients to safe levels and occurs any time the output capacitors ramp up. This is discussed in detail in the Soft Start section, below. The jumpers in the circuit ensure that the correct MOSFET switches are used for charging and discharging, thereby programming either positive or negative polarity input operation. The two jumpers must match – which is to say they must both be 'straight through' or 'crossed'.

### Caution

Both jumpers must be reversed, at the same time, otherwise serious damage may occur. Also make sure that the A,B,C terminal connections correspond to the new configuration, otherwise the SA306-IHZ will be destroyed when power is applied.

## Charge Dynamics

**Positive Converter** – For the positive converter configuration shown in Figure 3, inductor L1 is charged during the ON interval through the bottom MOSFET (Bb) switch. Inductor L1 sees  $V_{s-}$  on the left side and  $V_{bat}$  plus on the right; therefore, the current is essentially a ramp, as depicted in the figure because the voltage across the inductor is essentially constant and current is the integral of voltage. Then during the OFF interval the inductor discharges through the top MOSFET switch (Bt), exiting through terminal A to the attached load. Again, the same occurs for the A and C MOSFET switches during alternate cycles except their inputs are tied together, as shown in Figure 2, and therefore the At-Ct and Ab-Cb pairs are driven in unison.

**Negative Converter** – For the negative converter configuration shown below in Figure 4, inductor L1 is charged during the ON interval through the MOSFET (Bt) switch. When the Switch transfers to the "charge" mode, inductor L1 discharges through the bottom MOSFET switch (Bb) into the power ground. The same occurs for the A and C MOSFET switches during the alternate cycle except their inputs are tied together, as shown in Figure 2, and therefore At and Ct and Ab and Cb pairs are driven in unison.

**Buck Negative Converter** – This converter mode has the same charge dynamics as the negative converter. The difference is that power is applied via terminals A and C and removed via terminal B.

## Soft Start (Boost Only)

If there were no constraint when start up occurs, the input current would become very high because the circuit would attempt to immediately restore the low output voltage. In order to manage this scenario, the PWM, which behaves, in effect, as an error amplifier, is prevented from overreacting and instead the duty cycle is controlled so that the duty cycle rises slowly. As  $V_s$  comes up, it would normally pass through the 30 V zener diode D3 and adjustment potentiometer R8 to the junction – or duty cycle node – between Resistors R7 and R15. Instead the Soft Start node is connected directly to the output through D1 – C4 to  $V_{s+}$ , thereby bypassing the output of the converter sensed by the R8 – D3 network until the  $V_s$  potential is reached.

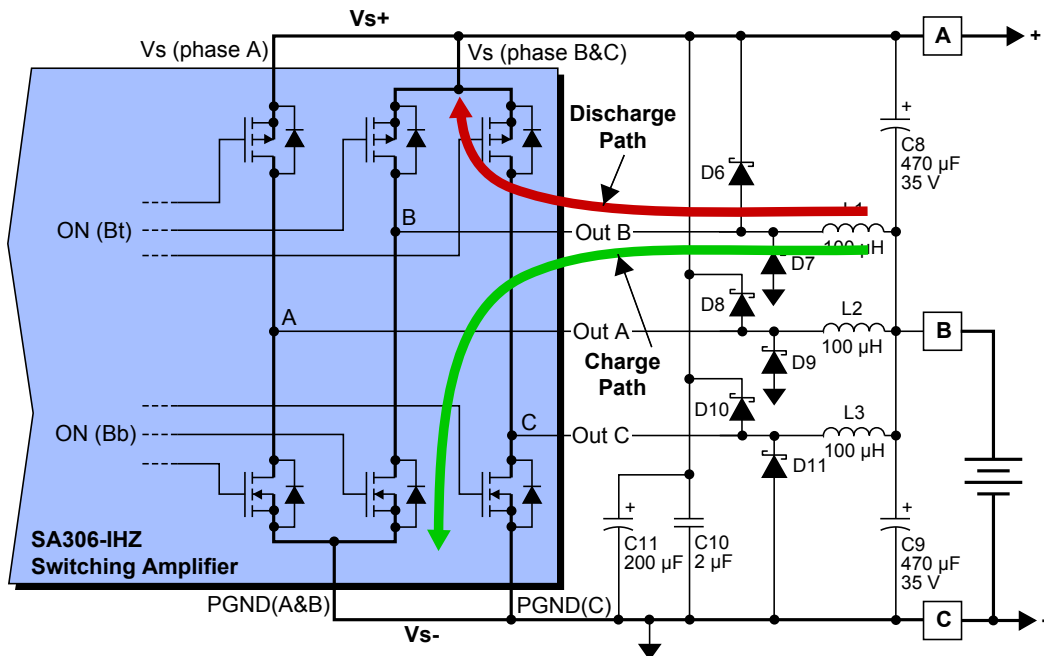

Figure 3 – Charge Dynamics – Positive Converter

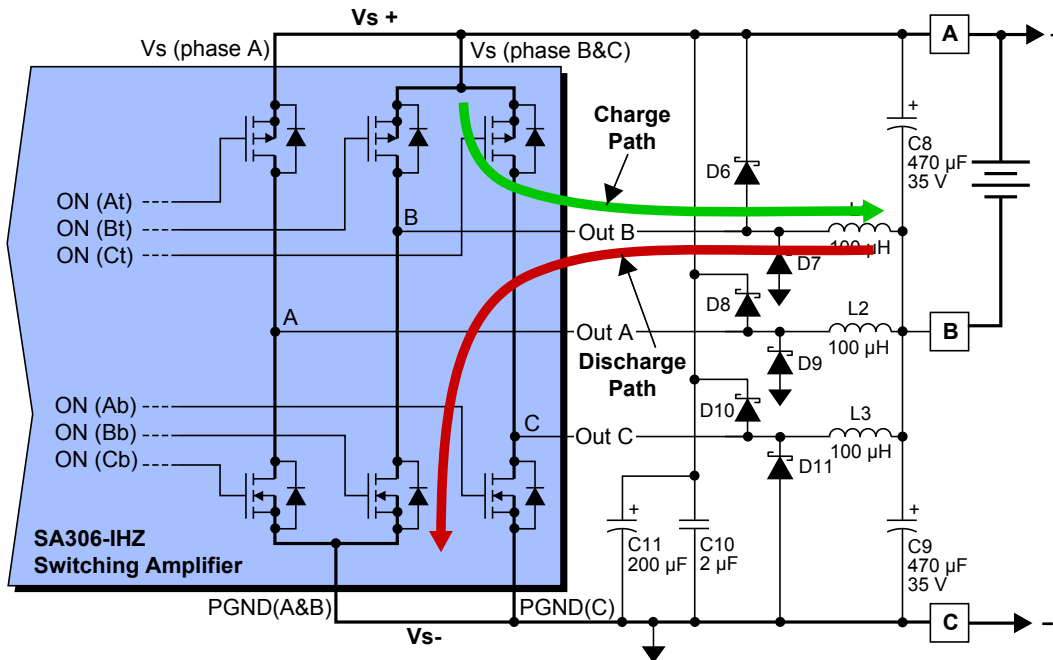

Figure 4 – Charge Dynamics – Negative Converter

## Steady-State Waveforms

As shown in Figure 5a, when the signal from the PWM turns on Bt, the current contribution to L1 during the previous cycle starts to decay (Iout waveform). When Bt goes OFF, and Bb goes ON, the current flows into inductor L1, rising in a linear fashion as depicted. By examining the actual composite waveform resulting from the contributions of both the B phase and the A-C phase (which behaves as a single-phase switch driving one half the inductance of 100 microhenries), ripple current is reduced. This is true because during the A and C discharge interval, the two inductances, L1 and L3, are connected in parallel. So the effective inductance becomes 50 microhenries. This accounts for the fact that the two currents rising and falling out of phase with each other, only partially wash each other out. So that the delivered current is a fairly steady 4 amperes, but with a slight ripple, as depicted in Figure 6.

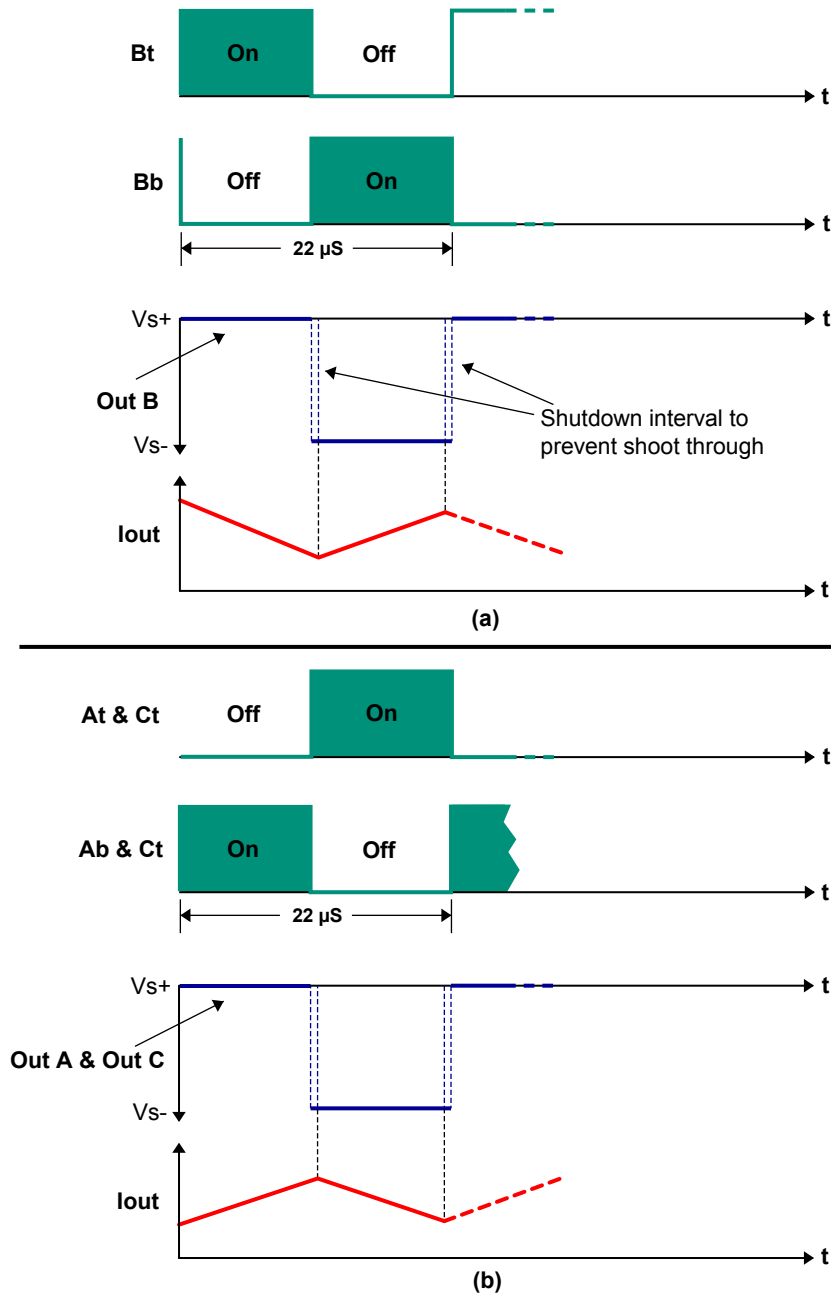

Figure 5 – (a) Phase B Discharge/Charge; (b) Phase A-C Charge/Discharge

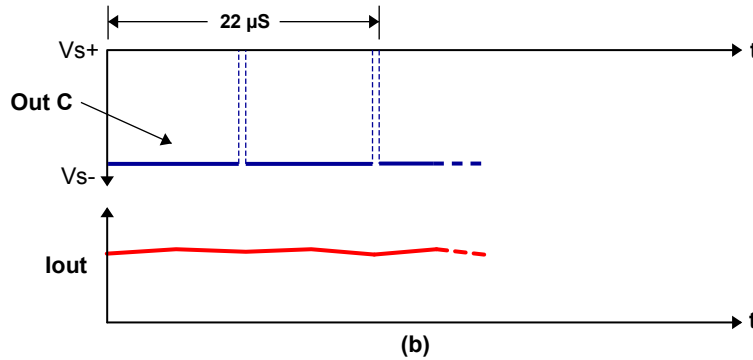

Figure 6 – Composite Waveforms – Phases A and B-C both delivering current

### Thermal Protection

Shown in Figure 7 is a circuit that could be added to “burp” the SA306-IHZ via DIS2 (no external latch) if a thermal overload is detected at TEMP pin 25.

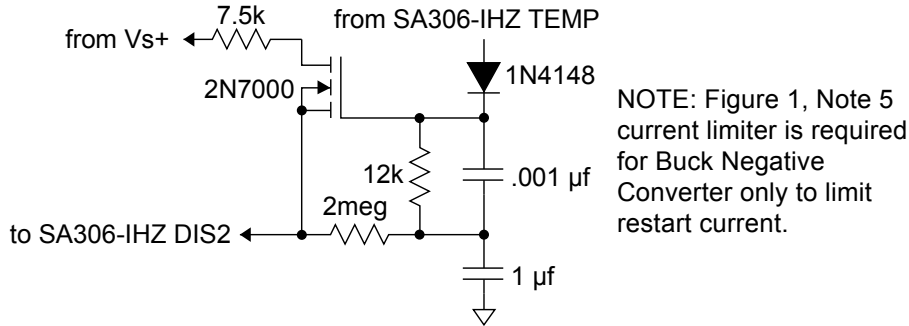

Figure 7 – Thermal Protection Circuit

An optional latch may be driven by the SA306-IHZ at TEMP pin 25 and its output could be used to shut down the converter via the DIS 1 pin 7, and/or shut down the 28 V supply in the event of a cooling failure. External current monitoring could also be gated to the same DIS1 pin 7 latch to protect the Boost Converter from load faults, etc. Note that pin 7 should be driven through a diode when current limiting is used (Buck mode only).

### Overvoltage Protection (Boost Only)

Over voltage protection is set by Potentiometer R9 so that limiting begins when the output reaches 57 V. This is essential because if there is no load connected, and the Boost Circuit is run off a 30 V power supply, it would be possible to obtain a 2 to 1 output voltage — plus, a small potential due to the inductance. This could destroy the SA306-IHZ. R9 should be set to maximum resistance when configured for Buck mode (Figure 1, Note 5).

## Miscellaneous Design Notes

**Capacitors C10 and C11** – Capacitors C10 and C11 are shown as bulk values in Figures 1, 3 and 4. These may be distributed between the Vs and the power ground terminals of the IC to provide adequate bypass.

**Overvoltage Shutdown** - The DIS2 pin 23 is employed to shut down the SA306-IHZ if a 1.7 V threshold at the pin is exceeded.

**Voltage Trimming the Output voltage** – Adjusting Potentiometer R8 enables trimming the output voltage slightly. The range is small because the shift in the duty cycle of the PWM (U2, U3) is small. The output voltage should be set to nominal with the output load set to one-half of its rated value to minimize the deviation from nominal under all load conditions.

**Measuring the Phase Currents** – Any of the phase currents can be measured by monitoring the voltage at the Ia, Ib, and Ic pins using a scope while the Boost Circuitry is configured as a negative converter and with the output loaded.

**Input Voltage is Limited to 30 V** – An input voltage above 30 V is not recommended without full characterization of the application. This is due to the fact the maximum duty factor is 50% and the output could conceivably rise above the 60 V rating of the SA306-IHZ under transient conditions.

**Other Voltage and Current Options** – It should be noted that the 30 V zener D3 could be changed to a 12 V zener (approximately) to configure a 20 V to 32 V and a 12 V, 8.5 A converter, for example.

**Buck Negative Converter** – Application of power should be done via inrush limiting circuitry due to the nominal 450  $\mu$ F input capacitance (input transient LC "ringing" 60V maximum).

## References

1. SA306-IHZ Pulse Width Modulation Amplifier Data Sheet, [www.cirrus.com](http://www.cirrus.com)
2. 3-Phase Switching Amplifier Application Note #46, [www.cirrus.com](http://www.cirrus.com)
3. TLC555 LinCMOS Timer, [www.ti.com](http://www.ti.com)

---

## CONTACTING CIRRUS LOGIC SUPPORT

For all Apex Precision Power product questions and inquiries, call toll free 800-546-2739 in North America.

For inquiries via email, please contact [tucson.support@cirrus.com](mailto:tucson.support@cirrus.com).

International customers can also request support by contacting their local Cirrus Logic Sales Representative.

To find the one nearest to you, go to [www.cirrus.com](http://www.cirrus.com)

---

### IMPORTANT NOTICE

Cirrus Logic, Inc. and its subsidiaries ("Cirrus") believe that the information contained in this document is accurate and reliable. However, the information is subject to change without notice and is provided "AS IS" without warranty of any kind (express or implied). Customers are advised to obtain the latest version of relevant information to verify, before placing orders, that information being relied on is current and complete. All products are sold subject to the terms and conditions of sale supplied at the time of order acknowledgment, including those pertaining to warranty, indemnification, and limitation of liability. No responsibility is assumed by Cirrus for the use of this information, including use of this information as the basis for manufacture or sale of any items, or for infringement of patents or other rights of third parties. This document is the property of Cirrus and by furnishing this information, Cirrus grants no license, express or implied under any patents, mask work rights, copyrights, trademarks, trade secrets or other intellectual property rights. Cirrus owns the copyrights associated with the information contained herein and gives consent for copies to be made of the information only for use within your organization with respect to Cirrus integrated circuits or other products of Cirrus. This consent does not extend to other copying such as copying for general distribution, advertising or promotional purposes, or for creating any work for resale.

CERTAIN APPLICATIONS USING SEMICONDUCTOR PRODUCTS MAY INVOLVE POTENTIAL RISKS OF DEATH, PERSONAL INJURY, OR SEVERE PROPERTY OR ENVIRONMENTAL DAMAGE ("CRITICAL APPLICATIONS"). CIRRUS PRODUCTS ARE NOT DESIGNED, AUTHORIZED OR WARRANTED TO BE SUITABLE FOR USE IN PRODUCTS SURGICALLY IMPLANTED INTO THE BODY, AUTOMOTIVE SAFETY OR SECURITY DEVICES, LIFE SUPPORT PRODUCTS OR OTHER CRITICAL APPLICATIONS. INCLUSION OF CIRRUS PRODUCTS IN SUCH APPLICATIONS IS UNDERSTOOD TO BE FULLY AT THE CUSTOMER'S RISK AND CIRRUS DISCLAIMS AND MAKES NO WARRANTY, EXPRESS, STATUTORY OR IMPLIED, INCLUDING THE IMPLIED WARRANTIES OF MERCHANTABILITY AND FITNESS FOR PARTICULAR PURPOSE, WITH REGARD TO ANY CIRRUS PRODUCT THAT IS USED IN SUCH A MANNER. IF THE CUSTOMER OR CUSTOMER'S CUSTOMER USES OR PERMITS THE USE OF CIRRUS PRODUCTS IN CRITICAL APPLICATIONS, CUSTOMER AGREES, BY SUCH USE, TO FULLY INDEMNIFY CIRRUS, ITS OFFICERS, DIRECTORS, EMPLOYEES, DISTRIBUTORS AND OTHER AGENTS FROM ANY AND ALL LIABILITY, INCLUDING ATTORNEYS' FEES AND COSTS, THAT MAY RESULT FROM OR ARISE IN CONNECTION WITH THESE USES.

Cirrus Logic, Cirrus, and the Cirrus Logic logo designs, Apex Precision Power, Apex and the Apex Precision Power logo designs are trademarks of Cirrus Logic, Inc. All other brand and product names in this document may be trademarks or service marks of their respective owners.