



PRODUCT MARKING

CE PACKAGE (T0-3),
DC, DD, CR, CU PACKAGE (M0-127 SERIES)
EL PACKAGE (DIP SERIES)

PA12M/883 _____ **LINE 1**

 _____ **LINE 2**

5962-XXXXXXXXXX _____ **LINE 3**

8A603 Q 0337 _____ **LINE 4**

Δ USA BeO _____ **LINE 5**

60024 _____ **LINE 6**

LINE 1

SMD* Parts: Apex Model Number
Standard Parts: Apex Model Number
Custom Parts: Blank

LINE 2

All Parts: APEX logo

LINE 3

SMD Parts: DSCC SMD Part Number
Standard Parts: Blank
Custom Parts: APEX Model Number

LINE 4

All Parts: Lot Code



Compliance Indicator



Q = DSCC QML Compliant
C = MIL-H-38534 Compliant
None = Not Compliant

Date Code

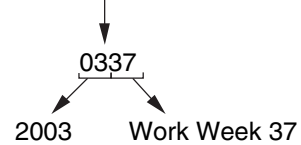

LINE 5

All Parts: Δ USA



(or) Δ USA BeO

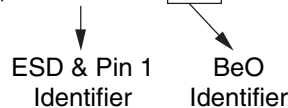

LINE 6

All Parts: 60024 = APEX CAGE Code

* SMD = Standardized Military Drawing



PRODUCT MARKING

DN, DP, DQ, DR, EC, ED, EE, EP, ET PACKAGE (HYBRID SIP SERIES)

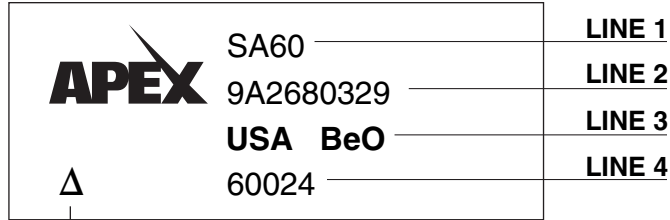

ESD & Pin 1 Identifier

LINE 1

SMD* Parts: Apex Model Number
Standard Parts: Apex Model Number
Custom Parts: Blank

LINE 2

All Parts: Lot Code

9A268

Date Code

0329

2003

Work Week 29

LINE 3

Made in U.S.A., BeO identifier

LINE 4

All Parts: 60024 = APEX CAGE Code

* SMD = Standardized Military Drawing



PRODUCT MARKING

DW PACKAGE (HERMETIC SIP)

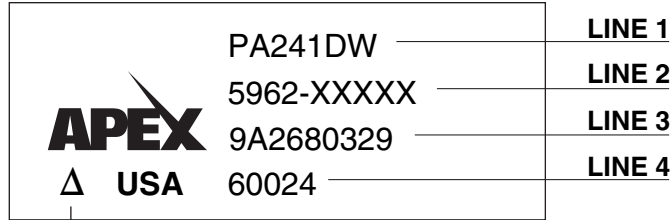

ESD & Pin 1
Identifier

LINE 1

SMD* Parts: Apex Model Number
Standard Parts: Apex Model Number
Custom Parts: Blank

Line 2

SMD Parts: DSCC SMD Part Number
Standard Parts: Blank
Custom Parts: APEX Model Number

LINE 3

All Parts: Lot Code

9A268

Compliance Indicator

Q

Q = DSCC QML Compliant
C = MIL-H-38534 Compliant
None = Not Compliant

Date Code

0329

2003

Work Week 29

LINE 4

All Parts: 60024 = APEX CAGE Code

* SMD = Standardized Military Drawing



PRODUCT MARKING

EU, EW PACKAGE (MONOLITHIC SIP)

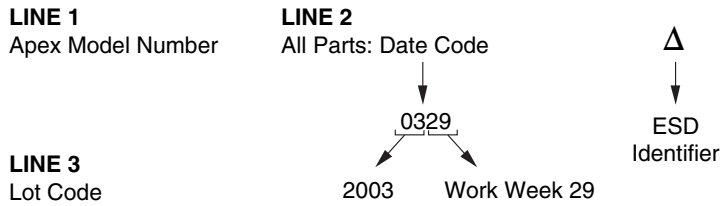

DF PACKAGE (24 PIN PSOP)

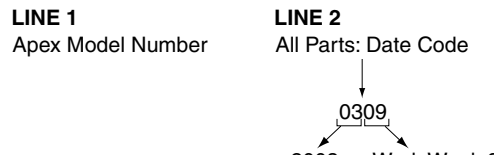
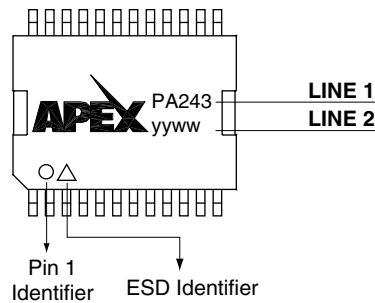

DK PACKAGE (20 PIN PSOP)

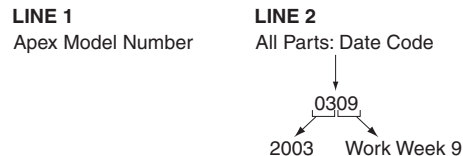
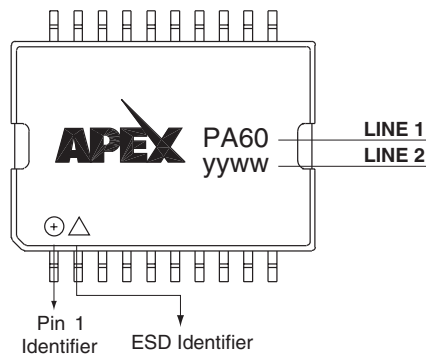

PRODUCT MARKING

**FN PACKAGE
(30 PIN PSOP)**

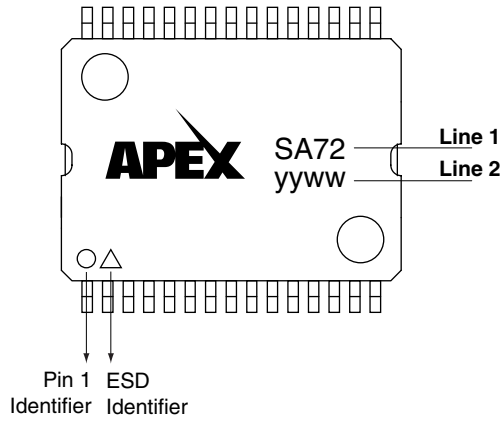

Line 1
Apex Model Number

Line 2
All Parts: Date Code

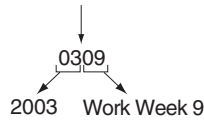

**CC PACKAGE
(7DDPAK)**

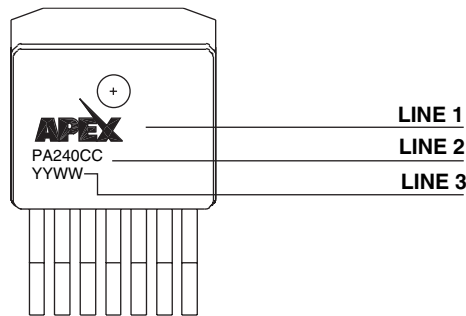

LINE 1
Apex Logo

LINE 3
All Parts: Date Code

LINE 2
Apex Part Number

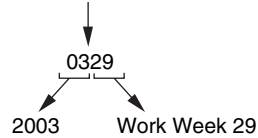



PRODUCT MARKING

HTTP://WWW.APEXMICROTECH.COM (800) 546-APEX (800) 546-2739

CD PACKAGE
(7T0220)
CX PACKAGE
(7T0220) STAGGERED PINS

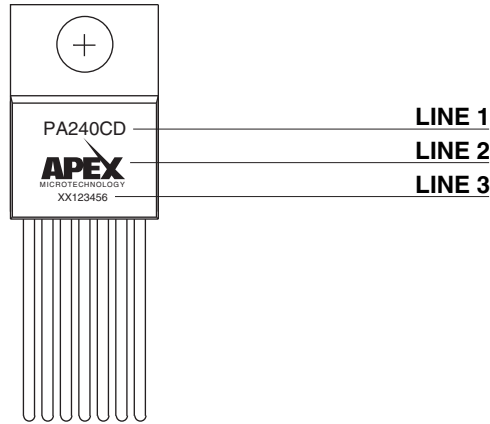

LINE 1
Apex Part Number

LINE 3
All Parts: Date Code

LINE 2
Apex Logo

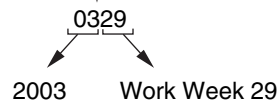

FQ PACKAGE
(16 PIN SOIC)

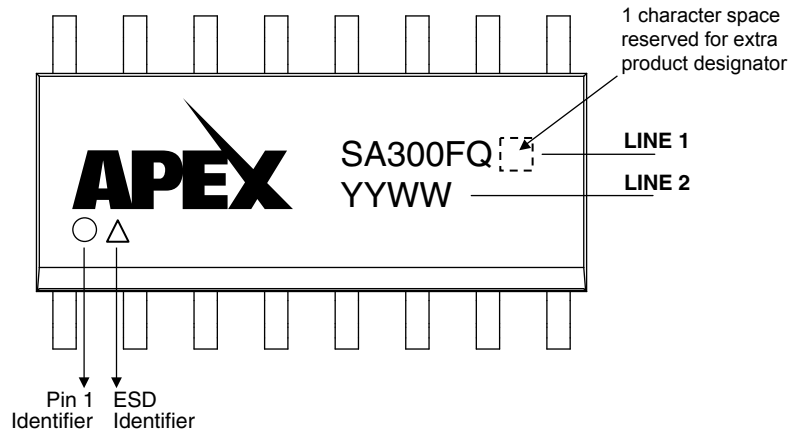

LINE 1
Apex Model Number

LINE 2
All Parts: Date Code

